

Compressibility of Lysozyme in Solution from Time-Resolved Brillouin Difference Spectroscopy*

W. DOSTER, B. SIMON, G. SCHMIDT, and W. MAYR, *Physik-Department E13, Technische Universität München, D-8046 Garching, Federal Republic of Germany*

INTRODUCTION

Brillouin scattering results from the interaction of light with sound waves. The Doppler shift of the scattered light is proportional to the speed of sound. Although Brillouin spectroscopy has been applied to biopolymers, collagen, and DNA fibers,^{1,2} such studies are rare and restricted to dry and slightly hydrated samples. It is desirable, however, to measure elastic properties of biomolecules in solution, since drying may lead to structural changes and hydration is essential for functional integrity. Such data can be obtained from ultrasound methods³⁻⁶ at megahertz frequencies. Light scattering, however, probes gigahertz phonons and thus bridges the gap between Raman scattering and ultrasound. Conventional Brillouin spectroscopy is not accurate enough to extract the properties of macromolecules in solution, since the Brillouin shift is dominated by the solvent. The frequency shift of a 10% protein solution relative to the solvent is about 200 MHz. We developed a method that directly measures this difference in frequency using optical heterodyne detection. Brillouin light scattered simultaneously from the solvent and a protein solution is superimposed on a fast photodiode. The signal then oscillates with the difference frequency. Enough photons for time-resolved measurements were produced with a pulse laser leading to stimulated scattering. The laser generates Stokes phonons in the sample above a threshold of about 1 MW/cm² by nonlinear optoacoustic coupling. The result is exponential amplification of the initially weak Brillouin light. Stimulated Brillouin scattering has been studied extensively (for a review, see Ref. 7). The difference method was used to measure the speed of sound in quartz for differently oriented crystals.⁸

We tested the method by measuring the sound velocity of several liquids relative to water. The results were in agreement with data obtained with spontaneous scattering. We also determined the apparent compressibility of lysozyme in solution at 2 GHz. The speed of sound, the adiabatic compressibility β_{ad} , and the density of a solution ρ are related by

$$c^2 = (\rho\beta_{ad})^{-1} \quad (1)$$

* This paper is dedicated to Dr. E. Lüscher on the occasion of his 60th birthday.

The apparent compressibility of the protein β_p^{app} is calculated from the difference in sound velocity and density between the solvent and the protein solution⁹:

$$\beta_p^{\text{app}}/\beta_0 = 2 - \rho_p/\rho_0 - 2(c - c_0)/c_0 v \quad (2)$$

where β_0 and ρ_0 are the compressibility and density of the solvent, ρ_p and v are the apparent density and the volume fraction of the solute, respectively. The relative excess sound velocity $(c - c_0)/c_0 v$ is determined to an accuracy of 10^{-2} , comparable with ultrasound.⁶ β_p^{app} is composed of two parts: the intrinsic protein compressibility, β_p , and a negative contribution due to bound water in the hydration shell^{3,6}:

$$\beta_p^{\text{app}} = \beta_p - k(\beta_0 - \beta_{\text{bw}}) \quad (3)$$

where k is the volume ratio of bound water to protein. The compressibility of bound water β_{bw} is much smaller than β_0 .^{3,6} β_p is a measure of volume fluctuations ΔV^2 of the protein^{9,10}:

$$\beta_p = \overline{\Delta V^2}/K_B TV - \alpha^2 T/c_p \quad (4)$$

The second term arises from the conversion of adiabatic to isothermal properties. It contains the coefficient of thermal expansion α and the volumetric specific heat. Changes of β_p^{app} can thus result from changes of dynamic properties (ΔV^2) or changes of hydration (k).

EXPERIMENTAL

Lysozyme (chicken egg, Boehringer and Sigma, Grade II), 100 mg, was dissolved in 1 mL of 0.1M phosphate or acetate buffer at the desired pH without further purification. Most of the protein was in a monomeric state, as judged from its diffusion coefficient by quasielastic light scattering. The density of the solvent and the solution were determined with a vibrating densitometer (accuracy, 10^{-5}).¹¹ The apparent density of lysozyme $\rho_p = 1.36 \text{ g/cm}^3$ at 20°C and the thermal expansion $dv_p/dT = 3.10^{-4} \text{ cm}^3/\text{K}$ are close to literature values.^{6,12} Figure 1 shows a scheme of the Brillouin difference spectrometer. The single-mode pulse (30 ns) of a 2-MW ruby laser is split and focused on a thermostated double chamber containing the solvent and the protein solution. The light scattered from both samples travels back ($\theta = 180^\circ$) and interferes on a photodiode. The beat is registered by photographing the trace on a fast oscilloscope. The signal is digitized and Fourier-transformed. The difference frequency can be determined to an accuracy of 8 MHz. This is roughly a factor of 10 better than can be achieved with conventional interferometry. It is essential that the frequency drift of the laser cancels exactly.

RESULTS and DISCUSSION

Figure 2 shows the interferogram and the real part of its Fourier transform. The Brillouin pulse follows the laser pulse (quasistationary conditions) but is modulated by the difference frequency. The linewidth of the difference spec-

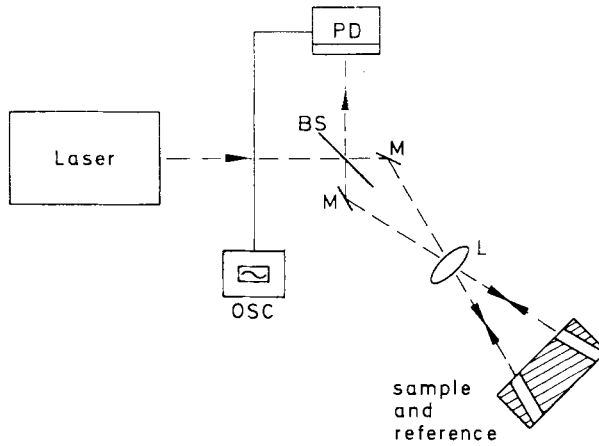

Fig. 1. Brillouin difference spectrometer: M, mirrors; BS, beam splitter; PD, photodiode (rise time, 0.2 ns); L, lens; OSC, oscilloscope.

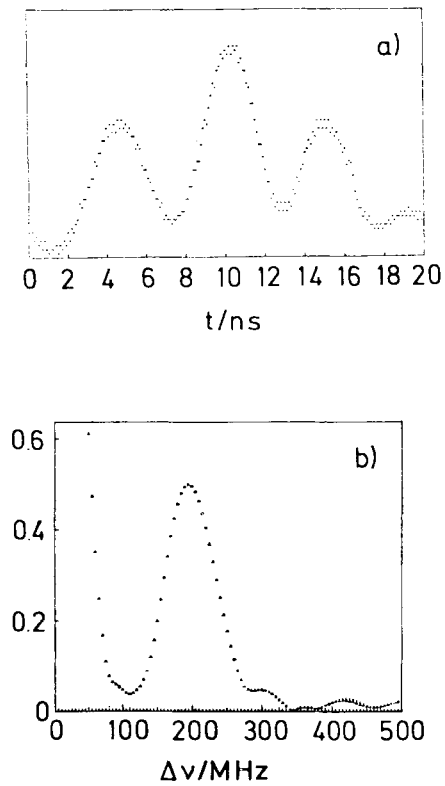

Fig. 2. (a) Digitized interferogram: reference, water; sample, a 10% (w/w) lysozyme solution. (b) Fourier transform of the interferogram.

trum is determined by the length of the Brillouin pulse. The line at zero frequency arises because the signal is positive everywhere. Figure 3 gives the difference Brillouin shift of a 10% lysozyme solution relative to water as a function of temperature. The difference frequency decreases with temperature but sharply increases again at the denaturation temperature of lysozyme. This temperature depends on the pH of the solution.¹³ The data indicate that our method is sensitive to structural changes of the protein. Figure 4 displays the temperature dependence of β_p^{app} relative to β_w ($= 4.55 \times 10^{-10} \text{ m}^2 \text{ N}^{-1}$ water, 20°C). The compressibility at 2 GHz near 20°C is smaller than that found at 1 MHz, although there is a slight overlap of the error bars.⁶ We suggest as a tentative explanation that some volume fluctuations of the protein are frozen out at the higher frequency. The temperature effect resembles the pH denaturation curve determined with ultrasound: an increase of β_p^{app} with increasing pH and a drop at the denaturation point.^{4,6} The increase was attributed to release of bound water due to neutralization of charges. Thermal release of bound water is more likely in our case, since the pH changes less than 0.1 units in this temperature range. The contribution of the solvent to β_p^{app} was estimated to be between 0.3 and 0.4 β_w .³ The nonlinear change with temperature suggests a cooperative release of water with a large enthalpic and entropic contribution from the protein. A second possibility is an increase of volume fluctuations near the transition point. The thermal expansion coefficient of lysozyme exhibits a minimum in this temperature range.¹² The authors suggest a loosening of the protein structure. The drop of β_p^{app} at the denaturation temperature is a measure of the intrinsic compressibility β_p if the compressibility of the denatured form is small. The drop of 0.15 β_w probably resulting from the loss of voids between elements of the secondary structure

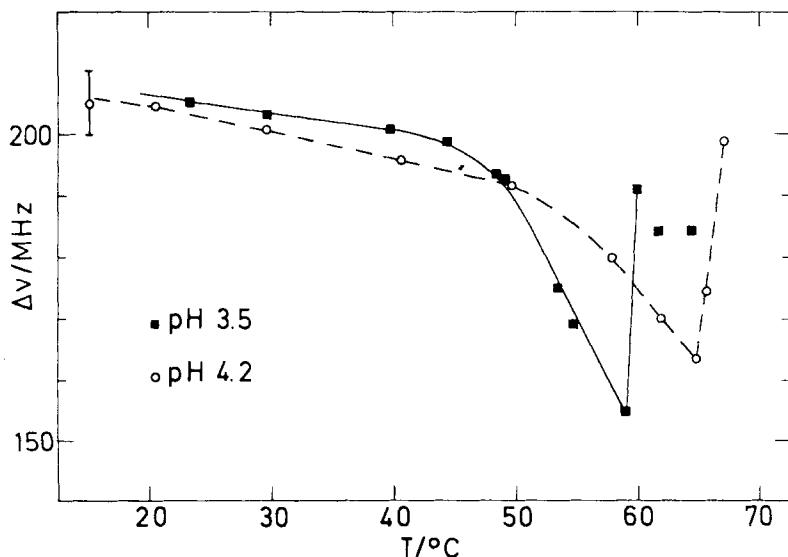

Fig. 3. Brillouin difference shift $\Delta\nu$ of a 10% lysozyme solution relative to water as a function of temperature: ■, pH 3.5; ○, pH 4.2.

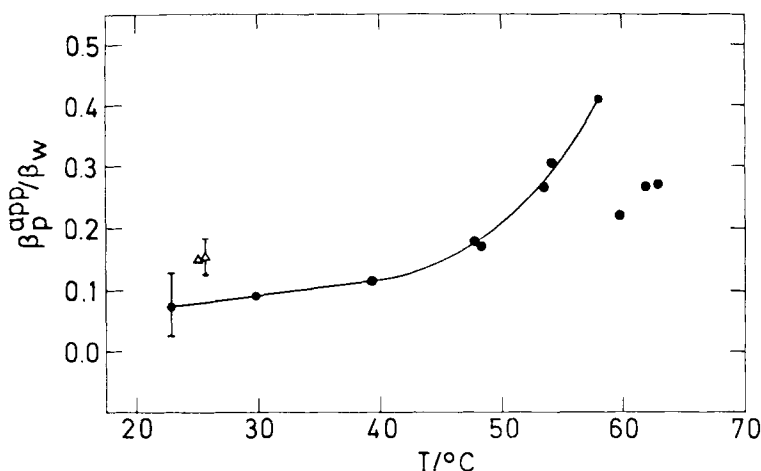

Fig. 4. Apparent compressibility of lysozyme (●) at 5 GHz, pH 3.5, relative to water at 20°C and data from Ref. 6 obtained at 1 MHz under similar conditions (△).

is close to the estimates obtained from pH denaturation of myoglobin with ultrasound. One has to keep in mind, however, that thermal denaturation of lysozyme does not yield completely disordered products.¹³

CONCLUSION

We have shown that time-resolved Brillouin scattering can be applied to macromolecules in solution. Frequency differences between 50 MHz and 2 GHz can be determined to an accuracy of 8 MHz. The concentration of polymer needed (10%) is still quite high for biochemical applications. Improvement by a factor of 10 seems technically feasible. Application of the method to other problems, where small Brillouin shifts are involved, is possible. The laser power has to be increased with increasing viscosity of the liquid, since the gain factor for stimulated scattering is proportional to the phonon lifetime.

We are grateful to Dr. E. Lüscher, Dr. P. Korpiun and D. Müller for helpful discussions and technical advice.

References

1. Cusack, S. & Lees, S. (1984) *Biopolymers* **23**, 337–351.
2. Maret, G., Oldenburg, R., Winterling, G., Dransfeld, K. & Rupprecht, A. (1979) *Coll. Polon. Sci.* **257**, 1017–1020.
3. Gekho, K. & Noguchi, H. (1979) *J. Phys. Chem.* **83**, 2706–2714.
4. Sarvazyan, A., Kharakoz, D. P. & Hemmes, P. (1979) *J. Phys. Chem.* **83**, 1796–1799.
5. Millero, F. J., Ward, G. K. & Chetirkin, P. (1976) *J. Biol. Chem.* **251**, 4001–4004.
6. Gavish, B., Gratton, E. & Hardy, C. J. (1983) *Proc. Natl. Acad. Sci. USA* **80**, 750–754.
7. Kaiser, W. & Maier, M. (1972) in *Laser Handbook*, Arrecchi F. T., & Schulz Du-Bois, E. V., Eds., North-Holland, Amsterdam, pp. 1079–1150.

8. Pelou, J., Vedel, C., Bouissier, M. & Cecchi, L. (1972) *Phys. Lett.* **38**, 73–74.
9. Cooper, A. (1976) *Proc. Natl. Acad. Sci. USA* **73**, 2740–2741.
10. Lee, B. (1983) *Proc. Natl. Acad. Sci. USA* **80**, 622–626.
11. Kratky, U., Leopold, H. & Stabinger, H. (1969) *Methods Enzymol.* **27**, 98–110.
12. Bull, H. B. & Breese, K. (1973) *Biopolymers* **12**, 2351–2356.
13. Aune, K. C. & Tanford, C. (1969) *Biochemistry* **8**, 4579–4584.

Received March 11, 1985

Accepted May 7, 1985